

## ON BUCKLING OF PRETWISTED COLUMNS

B. TABARROK and YUEXI XIONG

Department of Mechanical Engineering, University of Victoria, P.O. Box 1700, Victoria, B.C.,  
Canada V8W 2Y2

and

D. STEINMAN and W. L. CLEGHORN

Department of Mechanical Engineering, University of Toronto, Toronto, Ontario,  
Canada M5S 1A4

(Received 24 January 1989; in revised form 7 March 1989)

**Abstract**—Through the principle of total potential energy the equilibrium equations and associated boundary conditions for buckling analysis of pretwisted columns are derived and analytically solved. For statically determinate cases, solutions are obtained from two second-order differential equations in terms of bending moments. However, for statically indeterminate cases, force displacement relations must be invoked and solved along with the equilibrium equations. Results for four typical cases, two statically determinate and two indeterminate, are provided and the effect of the natural twist on the buckling loads is investigated.

### 1. INTRODUCTION

Consider a prismatic column with a rectangular cross-section, subjected to an axial load  $P$ . When  $P$  reaches a value equal to the first buckling load of the column, the column will buckle in its weaker plane. Let the second moments of area for the two flexural planes of the column be such that the column's second buckling mode (in 3-D space) takes place in the stronger plane. Now consider another column of the same cross-section and length but one which is naturally twisted. The effect of the twist is to couple the weak and the strong flexural planes. It is then intuitively evident that the first buckling load of the naturally twisted column will be higher than that of the prismatic column. Thus pretwisting has a beneficial effect on the buckling of columns. Some thought will reveal that the coupling of the two planes has the effect of reducing the second buckling load of the column. Thus twisting has a detrimental effect on the second buckling load. However, in practice the second buckling load is of little interest and one may conclude that pretwisting has a net beneficial effect.

Now a number of interesting questions can be posed. To what extent does the pretwisting increase the first buckling load? Does the buckling strength increase with the pretwist angle monotonically? Does it level off asymptotically? Can the decreasing second mode buckling load become equal to the increasing first buckling load for certain pretwist angles? In this study some of these questions are addressed.

The stability of pretwisted columns was first investigated by Ziegler (1948). In this study Ziegler derived the buckling equations for simply supported Euler columns. Later a more detailed analysis was outlined by Ziegler (1951) wherein the governing equations were derived for two different coordinate systems and a more complete treatment of the different possible boundary conditions was given. Lüscher (1953) solved Ziegler's equations for the case of a cantilevered column. Leipholz (1960) outlined a solution procedure for general boundary conditions. Frisch-Fay (1973) derived Ziegler's equations from a purely geometric viewpoint and confirmed Ziegler's original solution. In recent years most of the investigations on the buckling of pretwisted columns have been limited to finite element methods. Gupta and Rao (1978) have analysed the stability of tapered and twisted Timoshenko beams, while Celep (1984, 1985, 1986) has investigated the dynamic buckling of pretwisted beams under nonconservative loads.

In the present paper the governing equations for buckling of pretwisted columns are derived from an energy point of view and are solved analytically. Results for four typical boundary conditions are provided and discussed.

## 2. THE GOVERNING EQUATIONS

For conservative buckling problems energy methods provide a systematic approach for deriving the equilibrium equations and the associated boundary conditions. The definition of energy terms requires the relationships between force and kinematic quantities. These so-called constitutive equations were derived in some detail in Tabarrok and Xiong (1989). For the specific case of pretwisted columns they take the following forms

$$m_1 = EI_1(\theta'_1 - \tau_0\theta_2) \quad (1)$$

$$m_2 = EI_2(\theta'_2 + \tau_0\theta_1) \quad (2)$$

$$q_1 = kGA(u'_1 - \tau_0u_2 - \theta_2) \quad (3)$$

$$q_2 = kGA(u'_2 + \tau_0u_1 + \theta_1) \quad (4)$$

where  $m$  and  $q$  denote the moment and shear force quantities, respectively, and  $\theta_1, \theta_2$  are the (bending) rotations of the cross-section about the principal coordinates of the column (see Fig. 1). Likewise  $u_1, u_2$  are the displacements along  $x_1, x_2$ , respectively,  $\tau_0$  denotes the natural twist of the cross-sections, and  $k$  is the shear coefficient.

It is worth noting that the above equations represent the generalizations of the Timoshenko-type constitutive equations to pretwisted beams. Thus the rotations are independent of the slopes of the centreline, namely  $(-u'_2 - \tau_0u_1)$  and  $(u'_1 - \tau_0u_2)$ . This independence allows one to determine shear strains as

$$\gamma_1 = u'_1 - \tau_0u_2 - \theta_2 \quad (5)$$

$$\gamma_2 = u'_2 + \tau_0u_1 + \theta_1. \quad (6)$$

The strain energy of the beam which is made up of flexural and shear components may be expressed as

$$U = \frac{1}{2} \int_0^l \{EI_1(\theta'_1 - \tau_0\theta_2)^2 + EI_2(\theta'_2 + \tau_0\theta_1)^2 + kGA(u'_1 - \tau_0u_2 - \theta_2)^2 + kGA(u'_2 + \tau_0u_1 + \theta_1)^2\} ds. \quad (7)$$

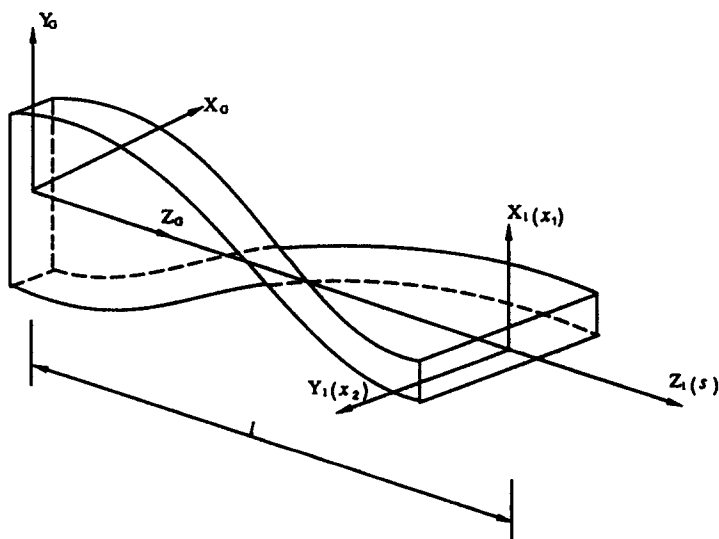

Fig. 1. The principal coordinates of the pretwisted column.

The potential energy of the external force may be expressed as

$$W = \frac{1}{2} \int_0^l \{P(u_1' - \tau_0 u_2')^2 + P(-u_2' - \tau_0 u_1')^2\} ds. \quad (8)$$

Now noting that the total potential energy is given by  $\Pi = U - W$  we may carry out variations of  $\Pi$  with respect to  $\theta_1$ ,  $\theta_2$ ,  $u_1$  and  $u_2$  to find the system equations:

$$\begin{aligned} \delta\Pi &= \delta U - \delta W \\ &= \int_0^l \{ \delta\theta_1 [-EI_1(\theta_1' - \tau_0\theta_2)' + \tau_0 EI_2(\theta_2' + \tau_0\theta_1) + kGA(u_2' + \tau_0 u_1 + \theta_1)] \\ &\quad + \delta\theta_2 [-EI_2(\theta_2' + \tau_0\theta_1)' - \tau_0 EI_1(\theta_1' - \tau_0\theta_2) - kGA(u_1' - \tau_0 u_2 - \theta_2)] \\ &\quad + \delta u_1 [-kGA(u_1' - \tau_0 u_2 - \theta_2)' + \tau_0 kGA(u_2' + \tau_0 u_1 + \theta_1) \\ &\quad + P(u_1' - \tau_0 u_2)' - \tau_0 P(u_2' + \tau_0 u_1)] \\ &\quad + \delta u_2 [-kGA(u_2' + \tau_0 u_1 + \theta_1)' - \tau_0 kGA(u_1' - \tau_0 u_2 - \theta_2) \\ &\quad + P(u_2' + \tau_0 u_1)' + \tau_0 P(u_1' - \tau_0 u_2)] \} ds \\ &\quad + \{ EI_1(\theta_1' - \tau_0\theta_2) \delta\theta_1 + EI_2(\theta_2' + \tau_0\theta_1) \delta\theta_2 \\ &\quad + [kGA(u_1' - \tau_0 u_2 - \theta_2) - P(u_1' - \tau_0 u_2)] \delta u_1 \\ &\quad + [kGA(u_2' + \tau_0 u_1 + \theta_1) - P(u_2' + \tau_0 u_1)] \delta u_2 \} \Big|_0^l. \end{aligned} \quad (9)$$

Thus the governing equations in the domain  $0 < s < l$  are given by

$$[kGA(u_1' - \tau_0 u_2 - \theta_2) - P(u_1' - \tau_0 u_2)]' - \tau_0 [kGA(u_2' + \tau_0 u_1 + \theta_1) - P(u_2' + \tau_0 u_1)] = 0 \quad (10)$$

$$[kGA(u_2' + \tau_0 u_1 + \theta_1) - P(u_2' + \tau_0 u_1)]' + \tau_0 [kGA(u_1' - \tau_0 u_2 - \theta_2) - P(u_1' - \tau_0 u_2)] = 0 \quad (11)$$

$$EI_1(\theta_1' - \tau_0\theta_2)' - \tau_0 EI_2(\theta_2' + \tau_0\theta_1) - kGA(u_2' + \tau_0 u_1 + \theta_1) = 0 \quad (12)$$

$$EI_2(\theta_2' + \tau_0\theta_1)' + \tau_0 EI_1(\theta_1' - \tau_0\theta_2) + kGA(u_1' - \tau_0 u_2 - \theta_2) = 0 \quad (13)$$

and the associate boundary conditions at  $s = 0$  and  $s = l$  are found as

$$EI_1(\theta_1' - \tau_0\theta_2) = 0 \quad \text{or} \quad \theta_1 \text{ is prescribed} \quad (14)$$

$$EI_2(\theta_2' + \tau_0\theta_1) = 0 \quad \text{or} \quad \theta_2 \text{ is prescribed} \quad (15)$$

$$kGA(u_1' - \tau_0 u_2 - \theta_2) - P(u_1' - \tau_0 u_2) = 0 \quad \text{or} \quad u_1 \text{ is prescribed} \quad (16)$$

$$kGA(u_2' + \tau_0 u_1 + \theta_1) - P(u_2' + \tau_0 u_1) = 0 \quad \text{or} \quad u_2 \text{ is prescribed.} \quad (17)$$

By using the constitutive equations (1)–(4) we can readily show that the governing equations in effect express the following equilibrium equations

$$[q_1 - P(u_1' - \tau_0 u_2)]' - \tau_0 [q_2 - P(u_2' + \tau_0 u_1)] = 0 \quad (18)$$

$$[q_2 - P(u_2' + \tau_0 u_1)]' + \tau_0 [q_1 - P(u_1' - \tau_0 u_2)] = 0 \quad (19)$$

$$m_1' - \tau_0 m_2 - q_2 = 0 \quad (20)$$

$$m_2' + \tau_0 m_1 + q_1 = 0. \quad (21)$$

For slender columns it is reasonable to neglect the shear strains. This requires a constraint relating the rotations to the centreline slopes [see eqns (5) and (6)]. If  $\gamma_1$  and  $\gamma_2$  are set equal to zero then from eqns (5)–(6), we have

$$\theta_1 = -u'_2 - \tau_0 u_1 \quad (22)$$

$$\theta_2 = u'_1 - \tau_0 u_2. \quad (23)$$

In this case, only  $m_1$ ,  $m_2$  and  $u_1$ ,  $u_2$  remain as independent variables. Thus the shear forces  $q_1$ ,  $q_2$  may be eliminated from the equilibrium equations (18)–(21) yielding the following two second-order equations in terms of  $m_1$ ,  $m_2$

$$m_2'' + 2\tau_0 m_1' - m_2 \left( \tau_0^2 - \frac{P}{EI_2} \right) = 0 \quad (24)$$

$$m_1'' - 2\tau_0 m_2' - m_1 \left( \tau_0^2 - \frac{P}{EI_1} \right) = 0. \quad (25)$$

The force–displacement relations for this case may be obtained by substituting eqns (22)–(23) into eqns (1)–(2), i.e.

$$m_1 = EI_1(-u''_2 - 2\tau_0 u'_1 + \tau_0^2 u_2) \quad (26)$$

$$m_2 = EI_2(u''_1 - 2\tau_0 u'_2 - \tau_0^2 u_1). \quad (27)$$

### 3. SOLUTION METHODS

Of the various combinations of boundary conditions, two leave the column in a statically determinate state. These are the pinned–pinned and the clamped–free ends. For these cases solutions may be obtained from the equilibrium equations directly. For the clamped–pinned and clamped–clamped boundary conditions the column is statically indeterminate—once in the first case and twice in the second. For these cases the satisfaction of the equilibrium equations is necessary but not sufficient. The force–displacement relations must be invoked to obtain solutions for these indeterminate cases.

Consider now the equilibrium equations. For the case of the Euler–Bernoulli model we showed that these are as given in eqns (24) and (25). The auxiliary equation for eqns (24) and (25) may be shown to take the following form

$$D^4 + \alpha D^2 + \beta = 0 \quad (28)$$

where

$$\alpha = \left( 2\tau_0^2 + \frac{P}{EI_1} + \frac{P}{EI_2} \right) \quad (29)$$

$$\beta = \left( \tau_0^2 - \frac{P}{EI_1} \right) \left( \tau_0^2 - \frac{P}{EI_2} \right). \quad (30)$$

The solutions for eqns (24), (25) take different forms depending upon whether  $\beta > 0$ ,  $\beta = 0$  or  $\beta < 0$ . For  $\beta > 0$  the four roots of the auxiliary equation are found to be imaginary yielding the following solutions

$$m_1 = c_1 \cos \lambda_1 s + c_2 \sin \lambda_1 s + c_3 \cos \lambda_2 s + c_4 \sin \lambda_2 s \quad (31)$$

$$m_2 = v_1 c_1 \sin \lambda_1 s - v_1 c_2 \cos \lambda_1 s + v_2 c_3 \sin \lambda_2 s - v_2 c_4 \cos \lambda_2 s \quad (32)$$

where

$$\lambda_1 = \left[ \frac{\alpha}{2} - \left( \frac{\alpha^2}{4} - \beta \right)^{1/2} \right]^{1/2} \quad (33)$$

$$\lambda_2 = \left[ \frac{\alpha}{2} + \left( \frac{\alpha^2}{4} - \beta \right)^{1/2} \right]^{1/2} \quad (34)$$

and

$$\begin{aligned} v_1 &= \frac{(\lambda_1^2 - 3\tau_0^2 - P/EI_1)\lambda_1}{2\tau_0(\tau_0^2 - P/EI_2)} \\ v_2 &= \frac{(\lambda_2^2 - 3\tau_0^2 - P/EI_1)\lambda_2}{2\tau_0(\tau_0^2 - P/EI_2)}. \end{aligned} \quad (35)$$

For  $\beta = 0$ , the auxiliary equation has two roots equal to zero and two imaginary roots. Thus in this case the solutions are as follows:

when  $P_1 = \tau_0^2 EI_1$

$$m_1 = c_1 + c_2 s + c_3 \cos \lambda_3 s + c_4 \sin \lambda_3 s \quad (36)$$

$$m_2 = v_3 c_2 - v_4 c_3 \sin \lambda_3 s + v_4 c_4 \cos \lambda_3 s \quad (37)$$

where

$$\lambda_3 = (\alpha)^{1/2} \quad (38)$$

$$v_3 = \frac{2\tau_0}{\tau_0^2 - P/EI_2}$$

$$v_4 = \frac{2\tau_0 \lambda_3 - \lambda_3^3 / 2\tau_0}{\tau_0^2 - P/EI_2} \quad (39)$$

when  $P_2 = \tau_0^2 EI_2$ ,

$$m_1 = -v_5 c_2 + v_6 c_3 \sin \lambda_3 s - v_6 c_4 \cos \lambda_3 s \quad (40)$$

$$m_2 = c_1 + c_2 s + c_3 \cos \lambda_3 s + c_4 \sin \lambda_3 s \quad (41)$$

where

$$v_5 = \frac{2\tau_0}{\tau_0^2 - P/EI_1}$$

$$v_6 = \frac{2\tau_0 \lambda_3 - \lambda_3^3 / 2\tau_0}{\tau_0^2 - P/EI_1}. \quad (42)$$

For  $\beta < 0$  the auxiliary equation has a pair of real roots and a pair of imaginary roots yielding the following solutions

$$m_1 = c_1 \cosh \lambda_4 s + c_2 \sinh \lambda_4 s + c_3 \cos \lambda_5 s + c_4 \sin \lambda_5 s \quad (43)$$

$$m_2 = v_7 c_1 \sinh \lambda_4 s + v_7 c_2 \cosh \lambda_4 s + v_8 c_3 \sin \lambda_5 s - v_8 c_4 \cos \lambda_5 s \quad (44)$$

where

$$\lambda_4 = \left[ \left( \frac{\alpha^2}{2} - \beta \right)^{1/2} - \frac{\alpha}{2} \right]^{1/2} \quad (45)$$

$$\lambda_5 = \left[ \left( \frac{\alpha^2}{2} - \beta \right)^2 + \frac{\alpha}{2} \right]^{1/2} \quad (46)$$

and

$$v_7 = \frac{(\lambda_4^2 + 3\tau_0^2 + P/EI_1)\lambda_4}{2\tau_0(\tau_0^2 - P/EI_2)}$$

$$v_8 = \frac{(\lambda_5^2 - 3\tau_0^2 - P/EI_1)\lambda_5}{2\tau_0(\tau_0^2 - P/EI_2)}. \quad (47)$$

In the above solutions the constants  $c_1 \sim c_4$  are to be determined from the boundary conditions.

### 3.1. Statically determinate cases

#### (a) Pinned-pinned column

For this case the boundary conditions are

$$m_1(0) = m_1(l) = 0$$

$$m_2(0) = m_2(l) = 0. \quad (48)$$

The satisfaction of these boundary conditions requires the vanishing of the following determinants.

For  $\beta > 0$

$$\det 1 = \begin{vmatrix} 1 & 0 & 1 & 0 \\ 0 & -v_1 & 0 & -v_2 \\ \cos \lambda_1 l & \sin \lambda_1 l & \cos \lambda_2 l & \sin \lambda_2 l \\ v_1 \sin \lambda_1 l & -v_1 \cos \lambda_1 l & v_2 \sin \lambda_2 l & -v_2 \cos \lambda_2 l \end{vmatrix}. \quad (49)$$

For  $\beta < 0$

$$\det 2 = \begin{vmatrix} 1 & 0 & 1 & 0 \\ 0 & v_7 & 0 & -v_8 \\ \cosh \lambda_4 l & \sinh \lambda_4 l & \cos \lambda_5 l & \sin \lambda_5 l \\ v_7 \sinh \lambda_4 l & v_7 \cosh \lambda_4 l & v_8 \sin \lambda_5 l & -v_8 \cos \lambda_5 l \end{vmatrix}. \quad (50)$$

For a column of particular geometry ( $l, I_1, I_2, \tau_0$ ) and material ( $E$ ) the quantities  $\alpha$  and  $\beta$  may be computed, for various values of  $\tau_0$ , from eqns (29), (30). From these the values of  $\lambda_1$  to  $\lambda_5$  and  $v_1$  to  $v_8$  may also be determined. Finally, the substitution of these quantities into det 1 and det 2 allows one to determine the loads for which det 1 and det 2 vanish. These loads are the critical loads.

It is worth noting that both det 1 and det 2 vanish for  $\beta = 0$  [see eqns (33), (35), (45), (47)]. However, as noted earlier these determinantal equations do not hold for the singular case of  $\beta = 0$ , i.e. the vanishing of det 1 and det 2 for values of  $P$  which render  $\beta = 0$ , do not necessarily indicate a buckling load. To check this case one must examine the determinants associated with  $\beta = 0$ . These are as follows:

for  $P_1 = \tau_0^2 EI_1$

$$\det 3 = \begin{vmatrix} 1 & 0 & 1 & 0 \\ 0 & v_3 & 0 & v_4 \\ 1 & l & \cos \lambda_3 l & \sin \lambda_3 l \\ 0 & v_3 & -v_4 \sin \lambda_3 l & v_4 \cos \lambda_3 l \end{vmatrix} \quad (51)$$

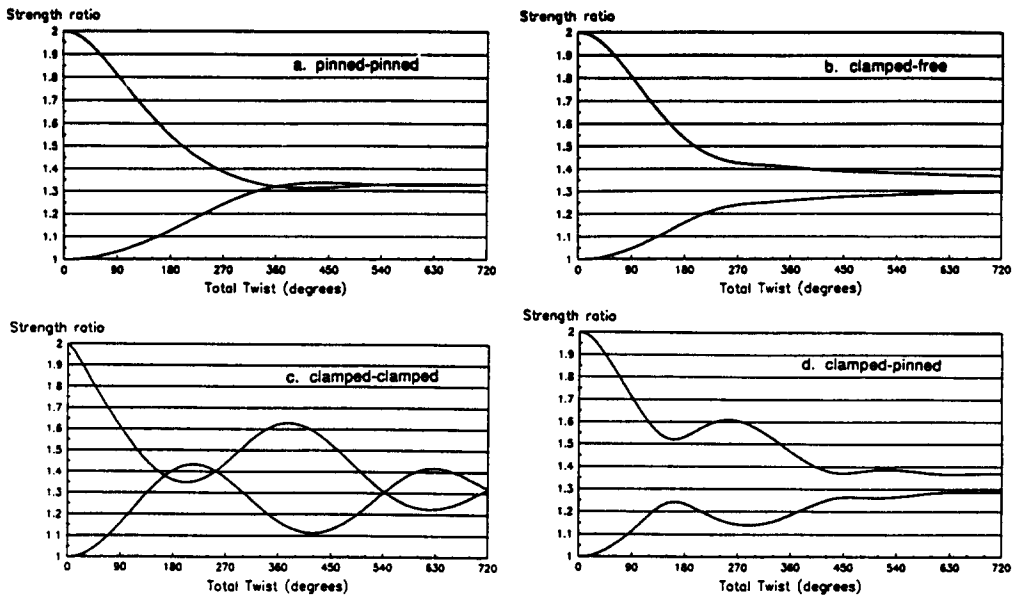

Fig. 2. Strength ratio vs total twist for pretwisted columns—(a) pinned–pinned ; (b) clamped–free ; (c) clamped–clamped ; (d) clamped–pinned.

for  $P_2 = \tau_0^2 EI_2$

$$\det 3 = \begin{vmatrix} 0 & -v_5 & 0 & -v_6 \\ 1 & 0 & 1 & 0 \\ 0 & -v_5 & v_6 \sin \lambda_3 l & -v_6 \cos \lambda_3 l \\ 1 & l & \cos \lambda_3 l & \sin \lambda_3 l \end{vmatrix} \quad (52)$$

For a given  $\tau_0$ , the vanishing of  $\beta$  fixes the value of  $P$ . For these values,  $\det 3$  can be evaluated and if it is found to vanish, say for  $P_1$ , then  $P_1$  is indeed a critical load, otherwise it is not. The same holds for  $P_2$ .

To bring out the effect of  $\tau_0$  on the buckling strength of the columns it is instructive to compute and plot the ratio of the critical loads of the twisted and prismatic columns against the total angle of twist, for a column of given  $l$  and  $I_2/I_1 (= \rho)$ . Such a plot is given in Fig. 2a. For this column  $I_2/I_1 = 2$ .

This plot exhibits the expected increase in the buckling strength for the first mode as the angle of twist is increased and a more rapid decrease in the buckling strength of the second mode. Close to  $360^\circ$  total twist, there is a confluence of the first and the second buckling modes. Thereafter the strength for the first buckling mode drops off slightly while that of the second mode increases slightly. This pattern is repeated, with smaller difference, for larger angles. These findings are in agreement with those reported by Frisch-Fay (1973).

In the limit as the angle of twist becomes quite large the first and the second buckling modes become coincident. From the plot of the strength ratio one can see that the asymptotic value of the first buckling load, at the large angles of twist, is 33% higher than that of the prismatic column, where  $I_2/I_1 = 2$ . This can be deduced as follows. For large  $\tau_0$  the buckling equations may be expressed as

$$u''_2 = -\frac{m_1}{EI_{av}} \quad \text{and} \quad u''_1 = \frac{m_2}{EI_{av}}$$

where  $I_{av}$  is the average second moment of area of the cross-section. Clearly

$$\frac{2}{I_{av}} = \frac{1}{I_1} + \frac{1}{I_2} \quad \text{or} \quad I_{av} = \frac{2I_1 I_2}{I_1 + I_2}$$

Thus for  $I_2/I_1 = 2$ , we find  $I_{av} = 4/3 I_1$ .†

† This point was raised by the reviewer.

(b) *Clamped-free column*

The boundary conditions for this case are

$$\begin{aligned} m_1(l) &= m_2(l) = 0 \\ q_1(0) &= (-m'_2 - \tau_0 m_1)|_0 = 0 \\ q_2(0) &= (m'_1 - \tau_0 m_2)|_0 = 0. \end{aligned} \quad (53)$$

The imposition of these boundary conditions leads to the following determinants

for  $\beta > 0$

$$\det 1 = \begin{vmatrix} \cos \lambda_1 l & \sin \lambda_1 l & \cos \lambda_2 l & \sin \lambda_2 l \\ v_1 \sin \lambda_1 l & -v_1 \cos \lambda_1 l & v_2 \sin \lambda_2 l & -v_2 \cos \lambda_2 l \\ -(v_1 \lambda_1 + \tau_0) & 0 & -(v_2 \lambda_2 + \tau_0) & 0 \\ 0 & (\lambda_1 + \tau_0 v_1) & 0 & (\lambda_2 + \tau_0 v_2) \end{vmatrix}, \quad (54)$$

for  $\beta < 0$

$$\det 2 = \begin{vmatrix} \cosh \lambda_4 l & \sinh \lambda_4 l & \cos \lambda_5 l & \sin \lambda_5 l \\ v_7 \sinh \lambda_4 l & v_7 \cosh \lambda_4 l & v_8 \sin \lambda_5 l & -v_8 \cos \lambda_5 l \\ -(v_7 \lambda_4 + \tau_0) & 0 & -(v_8 \lambda_5 + \tau_0) & 0 \\ 0 & (\lambda_4 - \tau_0 v_7) & 0 & (\lambda_5 + \tau_0 v_8) \end{vmatrix}, \quad (55)$$

for  $\beta = 0$ , when  $P_1 = \tau_0^2 EI_1$

$$\det 3 = \begin{vmatrix} 1 & l & \cos \lambda_3 l & \sin \lambda_3 l \\ 0 & v_3 & -v_4 \sin \lambda_3 l & v_4 \cos \lambda_3 l \\ -\tau_0 & 0 & v_4 \lambda_3 - \tau_0 & 0 \\ 0 & 1 - \tau_0 v_3 & 0 & \lambda_3 - \tau_0 v_4 \end{vmatrix}, \quad (56)$$

for  $\beta = 0$ , when  $P_2 = \tau_0^2 EI_2$

$$\det 3 = \begin{vmatrix} 0 & -v_5 & v_6 \sin \lambda_3 l & -v_6 \cos \lambda_3 l \\ 1 & l & \cos \lambda_3 l & \sin \lambda_3 l \\ 0 & -1 + \tau_0 v_5 & 0 & -\lambda_3 + \tau_0 v_6 \\ -\tau_0 & 0 & v_6 \lambda_3 - \tau_0 & 0 \end{vmatrix}. \quad (57)$$

For a column of geometry as given for the first example a plot of buckling strength ratio against twist angle is given in Fig. 2b. Once again the salient features of this plot are the increase in the buckling strength of the first mode and a larger decrease in that of the second mode. For this case though the confluence of the first two modes appears to occur asymptotically as the total angle of twist is made very large.

### 3.2. *Statically indeterminate cases*

As indicated earlier for the clamped-pinned and clamped-clamped cases, the force-displacement relations must be invoked. These relations are given in eqns (26) and (27). On eliminating  $u_2$  from eqns (26) and (27), we find the following differential equation

$$u_1'''' + 2\tau_0^2 u_1'' + \tau_0^4 u_1 = \frac{m_2''}{EI_2} - \frac{2\tau_0 m_1'}{EI_1} - \frac{\tau_0^2 m_2}{EI_2}. \quad (58)$$

It is necessary to determine the homogeneous and the particular solutions of this equation.



For the homogeneous solution the equation will have repeated roots given by  $\pm i\tau_0$ . Hence

$$u_{1h} = a_1 \cos \tau_0 s + a_2 \sin \tau_0 s + a_3 s \cos \tau_0 s + a_4 s \sin \tau_0 s. \quad (59)$$

To obtain the particular solution, the three cases of  $\beta > 0$ ,  $\beta = 0$  and  $\beta < 0$  must be examined separately. First, let us consider the case  $\beta > 0$ . For this case we may assume a particular solution of the following form

$$u_{1p} = a_5 \cos \lambda_1 s + a_6 \sin \lambda_1 s + a_7 \cos \lambda_2 s + a_8 \sin \lambda_2 s. \quad (60)$$

Substitution of the expressions for  $m_1$ ,  $m_2$  from eqns (31), (32) and  $u_{1p}$  from eqn (60) into eqn (58) allows one to determine  $a_5 \sim a_8$  as follows:

$$\begin{aligned} a_5 &= \mu_1 c_2, & a_6 &= -\mu_1 c_1 \\ a_7 &= \mu_2 c_4, & a_8 &= -\mu_2 c_3 \end{aligned} \quad (61)$$

where

$$\begin{aligned} \mu_1 &= \left[ \frac{v_1(\lambda_1^2 + \tau_0^2)}{EI_2} - \frac{2\tau_0\lambda_1}{EI_1} \right] / (\lambda_1^4 - 2\tau_0^2\lambda_1^2 + \tau_0^4) \\ \mu_2 &= \left[ \frac{v_2(\lambda_2^2 + \tau_0^2)}{EI_2} - \frac{2\tau_0\lambda_2}{EI_1} \right] / (\lambda_2^4 - 2\tau_0^2\lambda_2^2 + \tau_0^4). \end{aligned} \quad (62)$$

Therefore the general solution may be written as

$$\begin{aligned} u_1 &= a_1 \cos \tau_0 s + a_2 \sin \tau_0 s + a_3 s \cos \tau_0 s + a_4 s \sin \tau_0 s \\ &\quad - c_1 \mu_1 \sin \lambda_1 s + c_2 \mu_1 \cos \lambda_1 s - c_3 \mu_2 \sin \lambda_2 s + c_4 \mu_2 \cos \lambda_2 s \end{aligned} \quad (63)$$

where  $a_1 \sim a_4$  and  $c_1 \sim c_4$  are eight undetermined constants.

With the solutions for  $m_1$ ,  $m_2$  and  $u_1$  at hand we proceed to determine  $u_2$ . From eqns (26), (27) we deduce that

$$u_2 = \frac{1}{2\tau_0^3} \left( -\frac{m'_2}{EI_2} + 2\tau_0 \frac{m_1}{EI_1} + u_1''' + 3\tau_0^2 u_1' \right). \quad (64)$$

Substitution of eqns (31), (32), (63) into eqn (64) yields

$$\begin{aligned} u_2 &= -a_1 \sin \tau_0 s + a_2 \cos \tau_0 s - a_3 s \sin \tau_0 s + a_4 s \cos \tau_0 s \\ &\quad + c_1 \mu_3 \cos \lambda_1 s + c_2 \mu_3 \sin \lambda_1 s + c_3 \mu_4 \cos \lambda_2 s + c_4 \mu_4 \sin \lambda_2 s \end{aligned} \quad (65)$$

where

$$\begin{aligned} \mu_3 &= \frac{1}{2\tau_0^3} \left[ \frac{2\tau_0}{EI_1} - \frac{v_1\lambda_1}{EI_2} + \mu_1\lambda_1(\lambda_1^2 - 3\tau_0^2) \right] \\ \mu_4 &= \frac{1}{2\tau_0^3} \left[ \frac{2\tau_0}{EI_1} - \frac{v_2\lambda_2}{EI_2} + \mu_2\lambda_2(\lambda_2^2 - 3\tau_0^2) \right]. \end{aligned} \quad (66)$$

By a similar procedure we may obtain solutions for  $u_1$  and  $u_2$  for the cases of  $\beta = 0$  and  $\beta < 0$ . For sake of economy in space we simply provide the results as follows:

for  $\beta = 0$ , when  $P_1 = \tau_0^2 EI_1$

$$\begin{aligned} u_1 &= a_1 \cos \tau_0 s + a_2 \sin \tau_0 s + a_3 s \cos \tau_0 s + a_4 s \sin \tau_0 s \\ &\quad - c_2 \mu_5 + c_3 \mu_6 \sin \lambda_3 s - c_4 \mu_6 \cos \lambda_3 s \end{aligned} \quad (67)$$

$$u_2 = -a_1 \sin \tau_0 s + a_2 \cos \tau_0 s - a_3 s \sin \tau_0 s + a_4 s \cos \tau_0 s \\ + \frac{c_1}{\tau_0^2 EI_1} + \frac{c_2}{\tau_0^2 EI_1} s + c_3 \mu_7 \cos \lambda_3 s + c_4 \mu_7 \sin \lambda_3 s \quad (68)$$

where

$$\mu_5 = \left( \frac{2\tau_0}{EI_1} + \frac{\tau_0^2 v_3}{EI_2} \right) / \tau_0^4 \\ \mu_6 = \left( \frac{v_4 \lambda_3^2}{EI_2} + \frac{2\tau_0 \lambda_3}{EI_1} + \frac{\tau_0^2 v_4}{EI_2} \right) / (\lambda_3^4 - 2\tau_0^2 \lambda_3^2 + \tau_0^4) \\ \mu_7 = \left( \frac{v_4 \lambda_3}{EI_2} + \frac{2\tau_0}{EI_1} - \mu_6 \lambda_3^3 + 3\tau_0^2 \mu_6 \lambda_3 \right) / 2\tau_0^3 \quad (69)$$

for  $\beta = 0$ , when  $P_2 = \tau_0^2 EI_2$

$$u_1 = a_1 \cos \tau_0 s + a_2 \sin \tau_0 s + a_3 s \cos \tau_0 s + a_4 s \sin \tau_0 s \\ - \frac{c_1}{\tau_0^2 EI_2} - \frac{c_2}{\tau_0^2 EI_2} s - c_3 \mu_8 \sin \lambda_3 s - c_4 \mu_8 \cos \lambda_3 s \quad (70)$$

$$u_2 = -a_1 \sin \tau_0 s + a_2 \cos \tau_0 s - a_3 s \sin \tau_0 s + a_4 s \cos \tau_0 s \\ - c_2 \mu_9 - c_3 \mu_{10} \cos \lambda_3 s + c_4 \mu_{10} \sin \lambda_3 s \quad (71)$$

where

$$\mu_9 = \frac{4}{\tau_0^3 EI_2} + \frac{v_5}{\tau_0^2 EI_1} \\ \mu_{10} = \left( \frac{\lambda_3}{EI_2} + \frac{2\tau_0 v_6}{EI_1} - \mu_8 \lambda_3^3 + 3\tau_0^2 \mu_8 \lambda_3 \right) / 2\tau_0^3 \quad (72)$$

for  $\beta < 0$

$$u_1 = a_1 \cos \tau_0 s + a_2 \sin \tau_0 s + a_3 s \cos \tau_0 s + a_4 s \sin \tau_0 s \\ + c_1 \mu_{11} \sinh \lambda_4 s + c_2 \mu_{11} \cosh \lambda_4 s - c_3 \mu_{12} \sin \lambda_5 s + c_4 \mu_{12} \cos \lambda_5 s \quad (73)$$

$$u_2 = -a_1 \sin \tau_0 s + a_2 \cos \tau_0 s - a_3 s \sin \tau_0 s + a_4 s \cos \tau_0 s \\ + c_1 \mu_{13} \cosh \lambda_4 s + c_2 \mu_{13} \sinh \lambda_4 s + c_3 \mu_{14} \cos \lambda_5 s + c_4 \mu_{14} \sin \lambda_5 s \quad (74)$$

where

$$\mu_{11} = \left[ \frac{v_7(\lambda_4^2 - \tau_0^2)}{EI_2} - \frac{2\tau_0 \lambda_4}{EI_1} \right] / (\lambda_4^4 + 2\tau_0^2 \lambda_4^2 + \tau_0^4) \\ \mu_{12} = \left[ \frac{v_8(\lambda_5^2 + \tau_0^2)}{EI_2} - \frac{2\tau_0 \lambda_5}{EI_1} \right] / (\lambda_5^4 - 2\tau_0^2 \lambda_5^2 + \tau_0^4) \\ \mu_{13} = \left[ \frac{2\tau_0}{EI_1} - \frac{v_7 \lambda_4}{EI_2} - \mu_{11} \lambda_4 (\lambda_4^2 + 3\tau_0^2) \right] / 2\tau_0^3 \\ \mu_{14} = \frac{v_7(\lambda_4^2 - \tau_0^2)}{EI_2} - \frac{2\tau_0 \lambda_4}{EI_1} \quad (75)$$

With the general expressions for  $u_1$  and  $u_2$  derived, the eigenvalue formulations for specific cases may be obtained by imposing the related boundary conditions. These take the following forms:

(a) *Clamped-clamped column*

For this case, the boundary conditions are expressed as

$$\begin{aligned} u_1(0) = u_1(l) = u_2(0) = u_2(l) = 0 \\ u'_1(0) = u'_1(l) = u'_2(0) = u'_2(l) = 0. \end{aligned} \tag{76}$$

The imposition of these boundary conditions leads to the following determinants :

for  $\beta > 0$

$$\det 1 = \begin{vmatrix} 1 & 0 & 0 & 0 \\ 0 & \tau_0 & 1 & 0 \\ 0 & 1 & 0 & 0 \\ -\tau_0 & 0 & 0 & 1 \\ \cos \tau_0 l & \sin \tau_0 l & l \cos \tau_0 l & l \sin \tau_0 l \\ -\tau_0 \sin \tau_0 l & \tau_0 \cos \tau_0 l & \cos \tau_0 l - \tau_0 l \sin \tau_0 l & \sin \tau_0 l + \tau_0 l \cos \tau_0 l \\ -\sin \tau_0 l & \cos \tau_0 l & -l \sin \tau_0 l & l \cos \tau_0 l \\ -\tau_0 \cos \tau_0 l & -\tau_0 \sin \tau_0 l & -\sin \tau_0 l - \tau_0 l \cos \tau_0 l & \cos \tau_0 l - \tau_0 l \sin \tau_0 l \\ 0 & \mu_1 & 0 & \mu_2 \\ -\mu_1 \lambda_1 & 0 & -\mu_2 \lambda_2 & 0 \\ \mu_3 & 0 & \mu_4 & 0 \\ 0 & \mu_3 \lambda_1 & 0 & \mu_4 \lambda_2 \\ -\mu_1 \sin \lambda_1 l & \mu_1 \cos \lambda_1 l & -\mu_2 \sin \lambda_2 l & \mu_2 \cos \lambda_2 l \\ -\mu_1 \lambda_1 \cos \lambda_1 l & -\mu_1 \lambda_1 \sin \lambda_1 l & -\mu_2 \lambda_2 \cos \lambda_2 l & -\mu_2 \lambda_2 \sin \lambda_2 l \\ \mu_3 \cos \lambda_1 l & \mu_3 \sin \lambda_1 l & \mu_4 \cos \lambda_2 l & \mu_4 \sin \lambda_2 l \\ -\mu_3 \lambda_1 \sin \lambda_1 l & \mu_3 \lambda_1 \cos \lambda_1 l & -\mu_4 \lambda_2 \sin \lambda_2 l & \mu_4 \lambda_2 \cos \lambda_2 l \end{vmatrix} \tag{77}$$

for  $\beta < 0$

$$\det 2 = \begin{vmatrix} 1 & 0 & 0 & 0 \\ 0 & \tau_0 & 1 & 0 \\ 0 & 1 & 0 & 0 \\ -\tau_0 & 0 & 0 & 1 \\ \cos \tau_0 l & \sin \tau_0 l & l \cos \tau_0 l & l \sin \tau_0 l \\ -\tau_0 \sin \tau_0 l & \tau_0 \cos \tau_0 l & \cos \tau_0 l - \tau_0 l \sin \tau_0 l & \sin \tau_0 l + \tau_0 l \cos \tau_0 l \\ -\sin \tau_0 l & \cos \tau_0 l & -l \sin \tau_0 l & l \cos \tau_0 l \\ -\tau_0 \cos \tau_0 l & -\tau_0 \sin \tau_0 l & -\sin \tau_0 l - \tau_0 l \cos \tau_0 l & \cos \tau_0 l - \tau_0 l \sin \tau_0 l \\ 0 & \mu_{11} & 0 & \mu_{12} \\ \mu_{11} \lambda_4 & 0 & -\mu_{12} \lambda_5 & 0 \\ \mu_{13} & 0 & \mu_{14} & 0 \\ 0 & \mu_{13} \lambda_4 & 0 & \mu_{14} \lambda_5 \\ \mu_{11} \sinh \lambda_4 l & \mu_{11} \cosh \lambda_4 l & -\mu_{12} \sin \lambda_5 l & \mu_{12} \cos \lambda_5 l \\ \mu_{11} \lambda_4 \cosh \lambda_4 l & \mu_{11} \lambda_4 \sinh \lambda_4 l & -\mu_{12} \lambda_5 \cos \lambda_5 l & -\mu_{12} \lambda_5 \sin \lambda_5 l \\ \mu_{13} \cosh \lambda_4 l & \mu_{13} \sinh \lambda_4 l & \mu_{14} \cos \lambda_5 l & \mu_{14} \sin \lambda_5 l \\ \mu_{13} \lambda_4 \sinh \lambda_4 l & \mu_{13} \lambda_4 \cosh \lambda_4 l & -\mu_{14} \lambda_5 \sin \lambda_5 l & \mu_{14} \lambda_5 \cos \lambda_5 l \end{vmatrix} \tag{78}$$

for  $\beta = 0$ , when  $P_1 = \tau_0^2 EI_1$

$$\det 3 = \begin{vmatrix} 1 & 0 & 0 & 0 \\ 0 & \tau_0 & 1 & 0 \\ 0 & 1 & 0 & 0 \\ -\tau_0 & 0 & 0 & 1 \\ \cos \tau_0 l & \sin \tau_0 l & l \cos \tau_0 l & l \sin \tau_0 l \\ -\tau_0 \sin \tau_0 l & \tau_0 \cos \tau_0 l & \cos \tau_0 l - \tau_0 l \sin \tau_0 l & \sin \tau_0 l + \tau_0 l \cos \tau_0 l \\ -\sin \tau_0 l & \cos \tau_0 l & -l \sin \tau_0 l & l \cos \tau_0 l \\ -\tau_0 \cos \tau_0 l & -\tau_0 \sin \tau_0 l & -\sin \tau_0 l - \tau_0 l \cos \tau_0 l & \cos \tau_0 l - \tau_0 l \sin \tau_0 l \\ 0 & -\mu_5 & 0 & -\mu_6 \\ 0 & 0 & \mu_6 \lambda_3 & 0 \\ \frac{1}{\tau_0^2 EI_1} & 0 & \mu_7 & 0 \\ 0 & \frac{1}{\tau_0^2 EI_1} & 0 & \mu_7 \lambda_3 \\ 0 & -\mu_5 & \mu_6 \sin \lambda_3 l & -\mu_6 \cos \lambda_3 l \\ 0 & 0 & \mu_6 \lambda_3 \cos \lambda_3 l & \mu_6 \lambda_3 \sin \lambda_3 l \\ \frac{1}{\tau_0^2 EI_1} & \frac{l}{\tau_0^2 EI_1} & \mu_7 \cos \lambda_3 l & \mu_7 \sin \lambda_3 l \\ 0 & -\frac{1}{\tau_0^2 EI_1} & -\mu_7 \lambda_3 \sin \lambda_3 l & \mu_7 \lambda_3 \cos \lambda_3 l \end{vmatrix} \quad (79)$$

for  $\beta = 0$ , when  $P_2 = \tau_0^2 EI_2$

$$\det 3 = \begin{vmatrix} 1 & 0 & 0 & 0 \\ 0 & \tau_0 & 1 & 0 \\ 0 & 1 & 0 & 0 \\ -\tau_0 & 0 & 0 & 1 \\ \cos \tau_0 l & \sin \tau_0 l & l \cos \tau_0 l & l \sin \tau_0 l \\ -\tau_0 \sin \tau_0 l & \tau_0 \cos \tau_0 l & \cos \tau_0 l - \tau_0 l \sin \tau_0 l & \sin \tau_0 l + \tau_0 l \cos \tau_0 l \\ -\sin \tau_0 l & \cos \tau_0 l & -l \sin \tau_0 l & l \cos \tau_0 l \\ -\tau_0 \cos \tau_0 l & -\tau_0 \sin \tau_0 l & -\sin \tau_0 l - \tau_0 l \cos \tau_0 l & \cos \tau_0 l - \tau_0 l \sin \tau_0 l \\ -\frac{1}{\tau_0^2 EI_2} & 0 & 0 & -\mu_8 \\ 0 & -\frac{1}{\tau_0^2 EI_2} & -\mu_8 \lambda_3 & 0 \\ 0 & -\mu_9 & -\mu_{10} & 0 \\ 0 & 0 & 0 & \mu_{10} \lambda_3 \\ -\frac{1}{\tau_0^2 EI_2} & \frac{l}{\tau_0^2 EI_2} & -\mu_8 \sin \lambda_3 l & -\mu_8 \cos \lambda_3 l \\ 0 & -\frac{1}{\tau_0^2 EI_2} & -\mu_8 \lambda_3 \cos \lambda_3 l & \mu_8 \lambda_3 \sin \lambda_3 l \\ 0 & -\mu_9 & -\mu_{10} \cos \lambda_3 l & \mu_{10} \sin \lambda_3 l \\ 0 & 0 & \mu_{10} \lambda_3 \sin \lambda_3 l & \mu_{10} \lambda_3 \cos \lambda_3 l \end{vmatrix} \quad (80)$$

From the vanishing of the above determinants the first two critical loads of a column, with properties as listed earlier, were determined for various values of  $\tau_0$ . A plot of strength ratios against total angle of twist is given in Fig. 2c for this case. The plot exhibits the expected increase in the first mode and a corresponding decrease of the buckling load in the second mode. The notable difference between these plots and those of the statically determinate cases is the much magnified waviness in these plots. Evidently for small angles of twist the first buckling mode is associated with the weaker plane and the second with the stronger plane. At higher values of angle of twist the first buckling mode may be associated with the (original) stronger plane and *vice versa*, see for instance crossings of the plots in Fig. 2c. At the crossing points the first and second modes of buckling have the same value of buckling load.

(b) *Clamped-pinned column*

For this case, the boundary conditions are

$$\begin{aligned}
 u_1(0) = u_1(l) = u_2(0) = u_2(l) = u'_1(0) = u'_2(0) = 0 \\
 m_1(l) = EI_1(-u''_2 - 2\tau_0 u'_1 + \tau_0^2 u_2)|_l = 0 \\
 m_2(l) = EI_2(u''_1 - 2\tau_0 u'_2 - \tau_0^2 u_1)|_l = 0.
 \end{aligned}
 \tag{81}$$

In a similar manner the characteristic determinants may be deduced for this case and the critical loads may be calculated. For sake of brevity these lengthy determinants are not listed here. A plot of buckling strength ratios against total twist angle for this case is given in Fig. 2d.

In this case too the plots exhibit some waviness, the waves for the first and the second strength ratios are out of phase and they are attenuated at higher values of twist angles. The curves for the two strength ratios tend to coalesce asymptotically at a value of 33% above the buckling strength of the prismatic column.

From the determinants given above additional results can easily be generated. For instance the effect of  $\rho$  ( $= I_2/I_1$ ) on the strength ratios may be investigated. Figure 3 gives typical results for different values of  $\rho$ . Evidently the form of the strength ratio plots does not change but the value and the location of max and min points of the plots are effected by  $\rho$ .

Additional results, including some for the Timoshenko model, can be found in Steinman (1989) where an efficient program for determination of buckling loads has been outlined.

4. CONCLUDING COMMENTS

Through the principle of total potential energy the equilibrium equations and associated boundary conditions for buckling of pretwisted columns have been derived. These

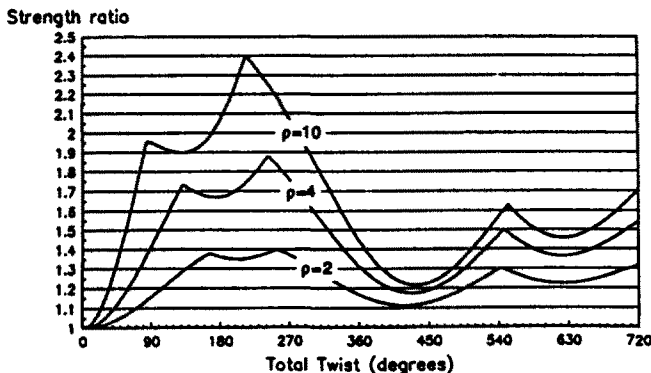

Fig. 3. Effect of  $\rho(I_2/I_1)$  on the first buckling mode of a clamped-clamped column.

equations, which are in the form of four coupled second-order differential equations in terms of lateral displacements and rotations, take account of shear strains. Accordingly these equations may be viewed as the generalizations of the Timoshenko beam models to pretwisted columns. For slender columns the shear strains may be suppressed allowing one to obtain Euler-type beam equations for pretwisted columns. These may be expressed as two coupled fourth-order equations in terms of displacements alone.

Through the force–displacement relations the Euler equilibrium equations were expressed by means of two coupled second-order differential equations in terms of bending moments. These equations, which are easier to solve, are sufficient for statically determinate cases. Solutions have been presented for two such cases, namely the pinned–pinned and clamped–free columns. For statically indeterminate cases the original two coupled fourth-order equations must be solved. An alternative but equivalent procedure has been employed in this study and solutions for clamped–clamped and clamped–pinned columns have been presented.

For all cases analyzed the effect of the natural twist is to increase the first buckling load and diminish the second. The plots of strength ratios, namely the ratio of buckling loads for twisted and prismatic columns, versus the total angle of twist indicate a coalescence of the first and second buckling loads as the total angle of twist increases. Depending upon the type of boundary conditions imposed these plots exhibit an oscillatory nature. The oscillations are more pronounced for the statically indeterminate cases.

Beam eigenvalue problems associated with conservative buckling and free vibrations have some characteristics in common. Thus curves showing increases in the fundamental frequencies and decreases in the second natural frequency have patterns not unlike those presented here. A set of such results was presented by Anliker and Troesch (1963).

#### REFERENCES

- Anliker, M. and Troesch, B. A. (1963). Lateral vibration of pretwisted rods with various boundary conditions. *ZAMP* **14**, 218–236.
- Celep, Z. (1984). Finite element stability analysis of pretwisted Beck's column. *Ingenieur-Archiv* **54**, 337–344.
- Celep, Z. (1985). Dynamic stability of pretwisted columns under periodic axial loads. *J. Sound Vibr.* **103**, 35–42.
- Celep, Z. (1986). Stability of pre-twisted Leipholz' column. *Acta Mech.* **60**, 157–170.
- Frisch-Fay, R. (1973). Buckling of pre-twisted bars. *Int. J. Mech. Sci.* **15**, 171–181.
- Gupta, R. S. and Rao, S. S. (1978). Finite element eigenvalue analysis of tapered and twisted Timoshenko beams. *J. Sound Vibr.* **56**, 187–200.
- Leipholz, H. (1960). Knickung verwunderner Stäbe unter Druck einer konservativen, kontinuierlich und gleichmäßig verteilten Belastung. *Ing-Arch.* **29**, 262–279.
- Lüscher, E. (1953). Bemerkungen zur Knickung des verwundenen, einseitig eingespanntenn Stabes. *Schweizerisch Bauzeitung* **71**, 172–173.
- Steinman, D. (1989). Exact solutions for the buckling analysis of pretwisted columns under various boundary conditions. MSc. Thesis, Department of Mechanical Engineering, University of Toronto.
- Tabarrok, B. and Xiong, Y. (1989). On the buckling equations for spatial rods. *Int. J. Mech. Sci.* **31**, 179–192.
- Ziegler, H. (1948). Die Knickung des verwundenen Stabes. *Schweizerisch Bauzeitung* **66**, 463–465.
- Ziegler, H. (1951). Stabilitätsprobleme bei geraden Stäben and Wellen. *ZAMP* **2**, 265–289.